

"SMX"- square cased mixed flow fan



- *Quality range mixed flow fan for commercial/industrial use*
- *5 sizes - casings from 450mm to 700mm square*
- *Airflow to 4.17m³/sec*
- *Pressure to 600Pa*
- *Single Phase - largest size Three Phase*
- *4 Pole Motors*
- *Speed Controllable*
- *Full range of accessories*

GENERAL

- For internal installation in industrial and commercial installations.
- High performance rates combined with low noise level
- Airflow to 4.17 m³/sec.
- Speed controllable using auto-transformer
- External rotor motors for reliability, quality and performance
- Flanged connection for quick and simple installation
- Unique, integral terminal box allows for electrical connections on two sides of casing to ensure flexibility during installation
- **ROOF MOUNTED MODELS ALSO AVAILABLE**

SPECIFICATION

- Robust construction with casing in 1mm thick galvanised sheet steel
- Motor is external rotor type, single or 3 phase, fitted with thermal overload protection to prevent overheating
- Integral motor/impeller assembly with impeller in polyamide for sizes 350-450 or aluminium for sizes 500 and 560
- Suitable for operation in air temperatures between -10°C and +60°C (Models SMX354M, SMX404M and SMX454M). Models SMX504M and SMX564T suitable for between -10°C and +40°C
- Motor/fan assembly is IP54 rated

COMPLY WITH

- Manufactured to ISO9001 in the UK
- EC Low Voltage Directive 73/23-93/68
- EC Directive EMC89/336

TYPICAL SPECIFICATION

Supply and install an SMX404M , 4 pole, single phase square cased, mixed flow fan as supplied by Vectaire Ltd, Lincoln Road, Cressex Business Park, High Wycombe, Bucks, HP12 3RH.

This fan is to be suitable for installation in commercial or industrial premises. It is to be speed controllable using an auto-transformer.

The casing should be in 1mm thick galvanised sheet steel, the motor to be of the external rotor type, single phase, fitted with thermal overload protection. The unit should be suitable for operation in air temperatures between -10°C and +60°C and have a motor/fan assembly with IP54 protection. Fan should be manufactured in UK to ISO9001.

RANGE

- **SMX354M**
4 pole, single phase
- **SMX404M**
4 pole, single phase
- **SMX454M**
4 pole, single phase
- **SMX504M**
4 pole, single phase
- **SMX564T**
4 pole, three phase



Tel: +44(0)1494 522333
Fax: +44(0)1494 522337

Vectaire Ltd
Lincoln Road, Cressex Business Park
High Wycombe, Buckinghamshire, HP12 3RH

Email: sales@vectaire.co.uk
Web: www.vectaire.co.uk

TECHNICAL CHARACTERISTICS



DIMENSIONS

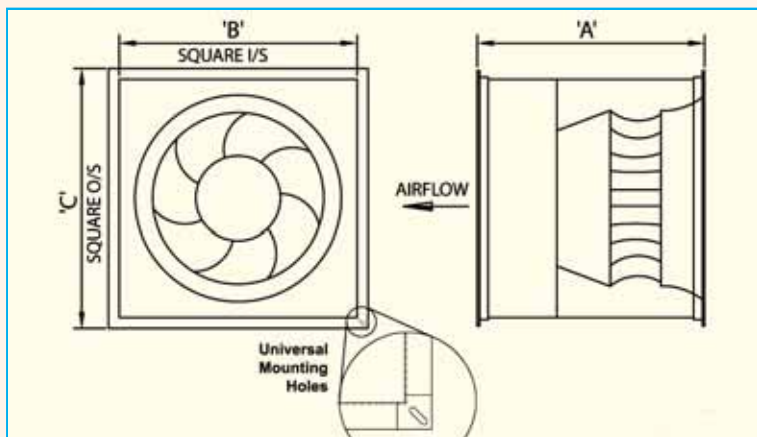

Model	A mm	B mm	C mm	Weight kg
SMX354M	400	450	500	18
SMX404M	435	500	550	26
SMX454M	505	550	620	35
SMX504M	535	661	731	45
SMX564T	570	700	770	54

PERFORMANCE

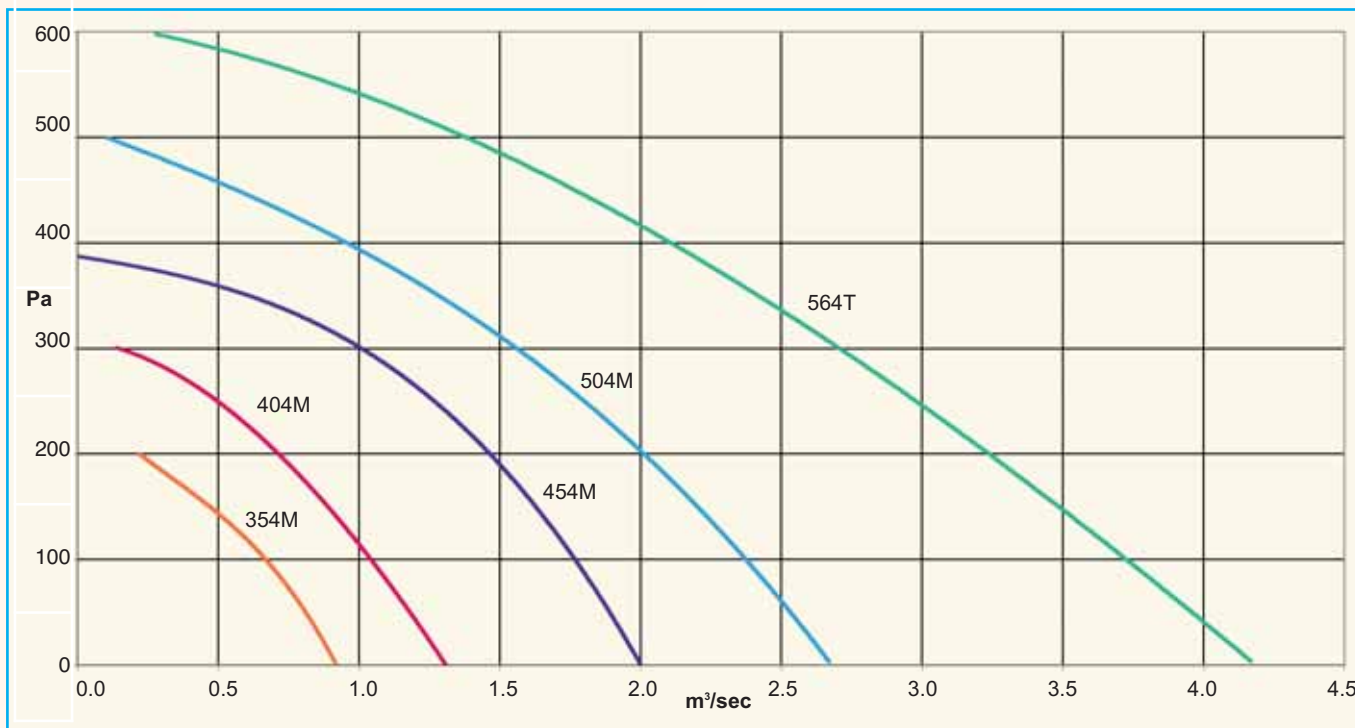

TECHNICAL DATA

Model	Supply	Pole	Power (W)	FLC (A)	SC (A)	dbA @ 3m	RPM	Max Airflow		Duty - m³/sec at Pa																
								m³/hr	cfm	0	50	100	150	200	250	300	350	400	450	500	550	600				
SMX354M	230v,1ph	4	310	1.35	3.7	53	1390	3312	1954	0.92	0.81	0.67	0.47	0.22	-	-	-	-	-	-	-	-	-	-	-	-
SMX404M	230v,1ph	4	460	2.0	5.0	59	1280	4716	2782	1.31	1.17	1.06	0.89	0.69	0.52	0.14	-	-	-	-	-	-	-	-	-	-
SMX454M	230v,1ph	4	910	4.4	9.2	61	1260	7200	4248	2.00	1.88	1.79	1.61	1.48	1.25	1.02	0.61	-	-	-	-	-	-	-	-	-
SMX504M	230v,1ph	4	1450	6.1	15.0	62	1310	9612	5671	2.67	2.56	2.35	2.20	2.00	1.81	1.59	1.28	0.94	0.56	0.11	-	-	-	-	-	-
SMX564T	415v,3ph	4	2400	4.3	20.0	69	1350	15012	8857	4.17	3.96	3.75	3.51	3.23	2.95	2.67	2.43	2.12	1.80	1.41	0.83	0.28	-	-	-	-

SOUND DATA

Model	Centre Frequency (Hz)							
	63	125	250	500	1,000	2,000	4,000	8,000
SMX354M	77	76	74	68	64	62	56	50
SMX404M	83	82	80	74	70	68	62	56
SMX454M	85	84	82	76	72	70	64	58
SMX504M	86	85	83	77	73	71	65	59
SMX564T	93	92	90	84	80	78	72	66

ACCESSORIES



Speed Controller/Transformers

A range of autotransformers/speed controllers for 1 and 3 phase models

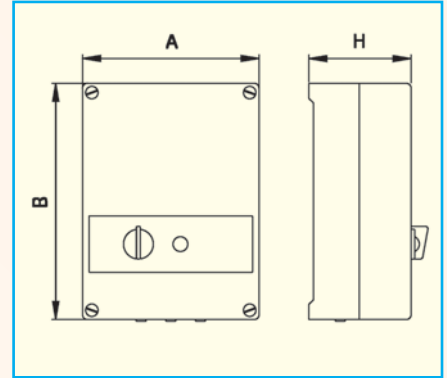
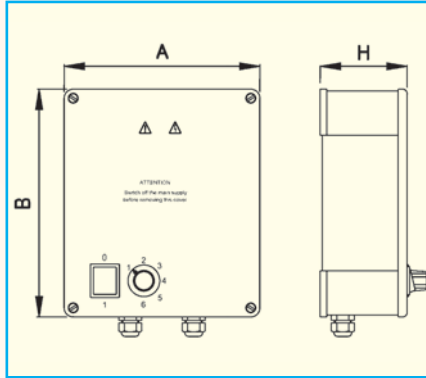

Model	A mm	B mm	H mm	Weight kg
VC1AM	142	166	66	2.5
VC4AM	216	252	96	5.0
VC7AM	262	312	126	8.3
VC7AT	253	316	143	20.0

Silencers

available for all sizes in 1000mm lengths as standard - other lengths available on request.

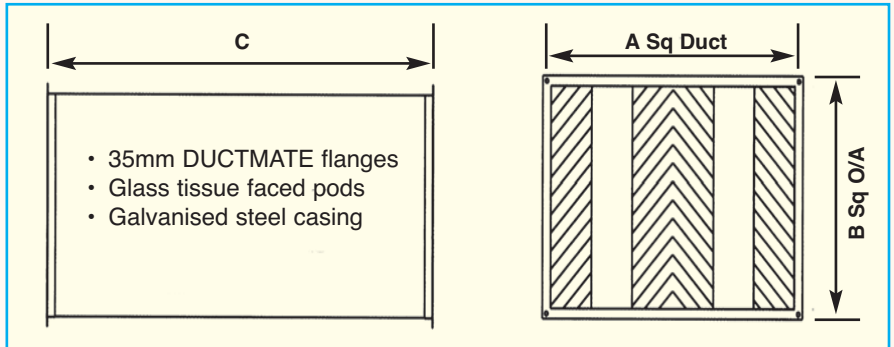

Model	Attenuation: Insertion loss - db - mid frequency Hz								Model	A mm	B mm	C mm
	63	125	250	500	1000	2000	4000	8000				
AS350	6	11	19	34	45	45	39	28	AS350	450	500	1000
AS400	5	9	16	30	39	39	31	26	AS400	500	550	1000
AS450	4	7	13	25	32	32	23	15	AS450	550	620	1000
AS500	4	7	13	25	32	32	23	15	AS500	661	731	1000
AS560	3	6	11	20	25	25	15	8	AS560	700	770	1000

Flexible Connectors

fitted with proprietary flange at each end to suit ductwork/fan. These are custom built for each size of fan and are 100mm in length.



Fan	Roof Mounted Models	Speed Controller Transformer	Attenuator	Double Flange Flexible Connector
SMX354M	RSMX354M	VC1AM	AS350	FDC350
SMX404M	RSMX404M	VC4AM	AS400	FDC400
SMX454M	RSMX454M	VC7AM	AS450	FDC450
SMX504M	RSMX504M	VC7AM	AS500	FDC500
SMX564T	RSMX564T	VC7AT	AS560	FDC560